

**Most
Dependable
Fountains, Inc.**

OPERATIONS MANUAL

**MODELS:
36 DB & 36 DBSS**

Most Dependable Fountains, IncTM
5705 Commander Drive
Arlington, TN 38002
800-552-6331
www.mostdependable.com



MOST DEPENDABLE FOUNTAINS, INC.
 5705 COMMANDER DR. P.O. BOX 587
 ARLINGTON, TN 38002-0587
 TOLL FREE: 1-800-552-6331
 PHONE: (901) 867-0039
 FAX: (901) 867-0159
 www.mostdependable.com

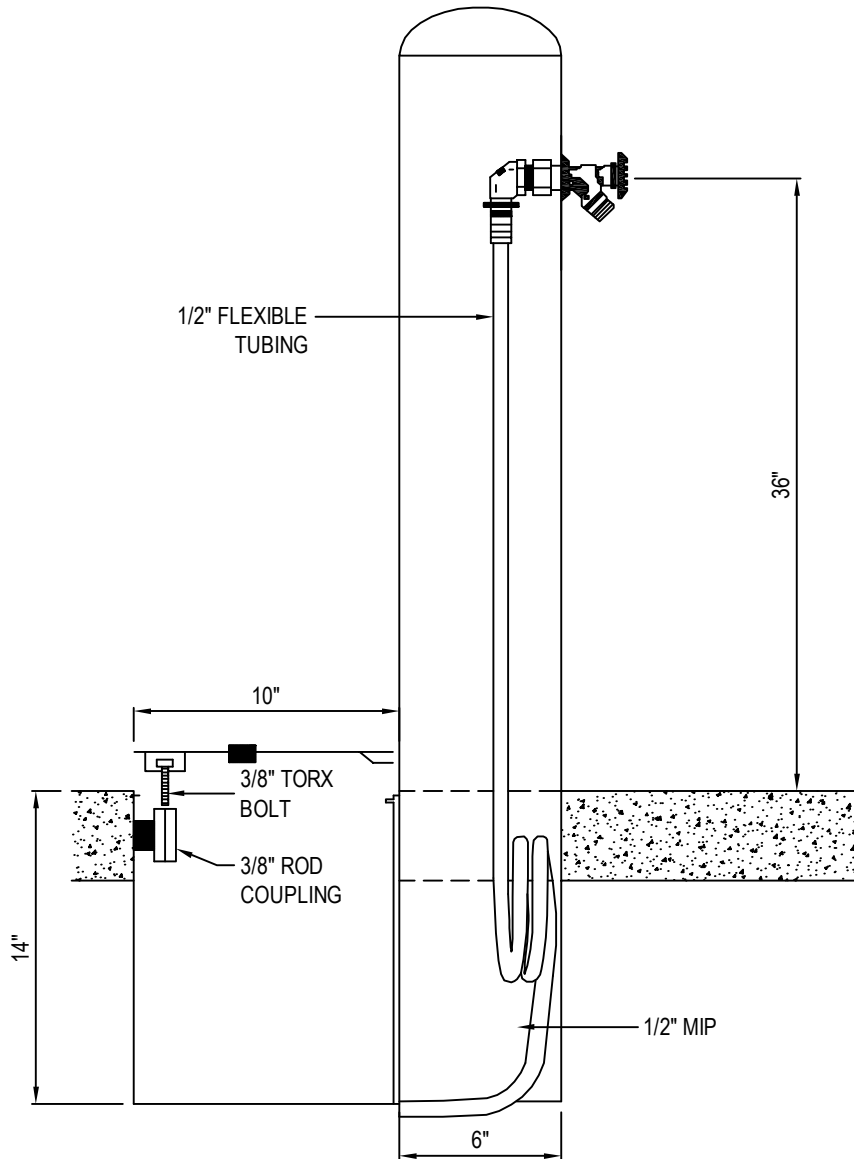

NOTES:

1. ATTACHED VALVE BOX IS STANDARD ON ALL DIRECT BURY HYDRANTS/HOSE BIBBS.
2. INSTALLATION TO BE COMPLETED IN ACCORDANCE WITH MANUFACTURER'S SPECIFICATIONS.
3. DO NOT SCALE DRAWING.
4. THIS DRAWING IS INTENDED FOR USE BY ARCHITECTS, ENGINEERS, CONTRACTORS, CONSULTANTS AND DESIGN PROFESSIONALS FOR PLANNING PURPOSES ONLY. THIS DRAWING MAY NOT BE USED FOR CONSTRUCTION.
5. ALL INFORMATION CONTAINED HEREIN WAS CURRENT AT THE TIME OF DEVELOPMENT BUT MUST BE REVIEWED AND APPROVED BY THE PRODUCT MANUFACTURER TO BE CONSIDERED ACCURATE.
6. CONTRACTOR'S NOTE: FOR PRODUCT AND COMPANY INFORMATION VISIT www.CADdetails.com/info AND ENTER REFERENCE NUMBER 3354-13.4.

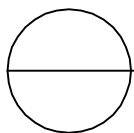

MODEL 36 DB

DIRECT BURY WITH ATTACHED VALVE BOX



HYDRANT SPECIFICATIONS

■ **STANDARD PEDESTAL**
OR
■ **STAINLESS STEEL PEDESTAL**

One piece weld construction with MDF standard 3/16" wall thickness OR
One piece weld construction with MDF standard 304 schedule 10 stainless steel.

FAUCET

Supplied with 3/4" anti-siphon vacuum breaker, frost resistant sill cock with removable handle.

FINISH

Oven baked powder coat. Choice of colors are: green, blue, black, red, yellow, orange, brown and white. Textured color choices: emerald, sapphire, pyrite, text-black, burgundy, gold vein, copper and sand-stone. Stainless steel models are powder coated for added protection. The color chrome is available for stainless steel models only.

INSTALLATION

Surface Mount units anchor to a concrete pad through a welded mounting plate. SS surface carriers recommended for all new installations. Flush all new or existing supply lines prior to installation. 10" bury in ground for **Direct Bury** models. All direct bury models include an attached valve box with bolted cover.

WINTERIZATION

Shut off water and drain down.

WARRANTY

One year warranty, labor not included.

SHIPPING WEIGHTS

Model 24 SM..... 48 lbs.
Model 24 SMSS.... 48 lbs.

Model 36 SM..... 58 lbs.
Model 36 SMSS.... 58 lbs.

MOST DEPENDABLE FOUNTAINS, INC.™

(800) 552-6331 • (901) 867-0039 • Fax (901) 867-4008

5705 COMMANDER DR. • ARLINGTON, TN 38002-0587

www.mostdependable.com

INSTALLATION INSTRUCTIONS

Most Dependable Fountains, Inc.™

All **SM (surface mount)** products are designed to be installed on the surface of a new or existing concrete slab. Your contractor needs to provide a 1 ½” PVC drain line (**when applicable**) and water line thru finish grade. Connections are made to our SM products thru our access door, as shown on detail drawings. The water tubing is provided with a ½” male iron pipe connection. This is an excellent location for a cutoff valve. Surface Mount units are anchored to the existing concrete by means of ½” concrete shields with bolts or we recommend ½” quick bolts.

Note: We offer an optional template which is designed to be poured in the concrete slab. It comes with the necessary vandal resist stainless steel bolts and washers need to anchor.

All **DB (direct bury)** products are designed to be installed to a depth of 14” below grade. MDF provides 1 ½” PVC drain line inside the pedestal (**when applicable**) to point of connection by others. MDF also provides reinforced nylobraid flexible tubing with a ½” male iron pipe thread for connection to water supply by others. MDF recommends an optional valve box using a PVC conduit to the pedestal. By using this option you have complete control of your product.

Individual detail drawings available Online or by request.



For more information:
Most Dependable Fountains, Inc.™
www.mostdependable.com
Info@mostdependable.com
800-552-6331
901-867-0039

LIMITED PRODUCT WARRANTY

Most Dependable Fountains, Inc.™

Most Dependable Fountains, Inc.™ warrants that all of its products are guaranteed against defective material or poor workmanship for a period of **one year from date of shipment**. Most Dependable Fountains, Inc.™ liability under this warranty shall be discharged by furnishing without charge any goods, or part thereof, which shall appear to the Company upon inspection to be of defective material or not of first class workmanship. Most Dependable Fountains, Inc.™ will not be liable for the cost of repairs, alterations or replacements, or for any expense connected therewith made by the owner or his agents. Most Dependable Fountains, Inc.™ will not be liable for any damages caused by defective materials or poor workmanship, except for replacements, as provided above. Buyer agrees that Most Dependable Fountains, Inc.™ has made no other warranties either expressed or implied in addition to those above stated. The products manufactured by Most Dependable Fountains, Inc.™ is warranted to function if installation and maintenance instructions provided are adhered to. The units also must be used for the purpose for which they were intended.

